

# CAPACITY.

## TJ7000 Trailer Jockey® Off Road Terminal Tractor

At Capacity of Texas, we believe a spotting tractor is only as good as its comfort, price and durability. That's why our ISO 9001 tractors continue to be *the most durable spotting tractors in the industry.*

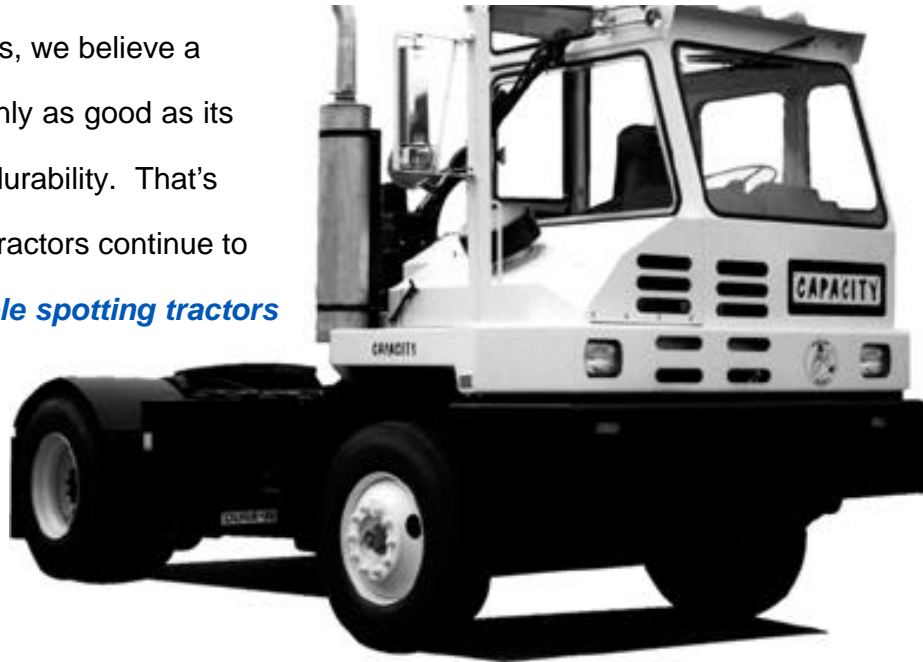

Some items shown in photograph represent optional equipment

### The Capacity Dura-Built™ Difference

- Exclusive Dura-Ride® Air Spring Suspension System Available
- Dedicated Cab Platform with Complete In-House Cab Construction
- High Strength Frame, RBM 4,248,960 In. Lbs.
- Exclusive Dura-Plus™ 10-Year Frame Warranty Available
- Durable Metal Dash with Printed Circuit Board
- Exclusive Lifetime Paint Warranty
- Models Available for Immediate Delivery

## Standard Features

Engine	Cummins 6BTAA 5.9L Elite 173 HP, EPA Industrial Turbo Diesel
Transmission	Allison MD3060 Electronic Automatic
Front Axle	Meritor FF961, 12,000 lb,
Rear Axle	Meritor RS30-380, 10.62:1, 42,000 lb, Double Reduction
Wheelbase	116"
Steering	Hydrostatic, Power
Fifth Wheel	Holland FW35, 70,000 lb.
Lift Cylinders	5", 70,000 lb. Hydraulic
Tires	11 X 22.5 16 Ply
Exhaust	Vertical
Paint	Cab White, Frame Black, Rims White

## Cab Features

VISTA IIE 60, Comfort Cab  
 Electric Cab Tilt  
 Seat Belt  
 Electronic Back-up Alarm  
 Tinted Glass  
 Level Sweep-out Cab Floor  
 Gauges: Air, Fuel, Hour, Volt, Temp and Oil  
 Back-lit Instrument Panel with DOT Icons  
 High Strength Metal Dash  
 w/Printed Circuit Board  
 Insulated Firewall Covering (engine side)  
 45,000 BTU Heater/Defroster/Fresh Air  
 Overhead Storage Compartment  
 Pop Open Vent (front quarter panel)  
 Electric Windshield Wipers  
 Air Intake Restriction Indicator (Engine Mount)

## Frame Features

ASTM A529 12" X 3" Preformed Structural Steel  
 RBM 4,248,960 In. Lbs.  
 50 Degree Tapered Bumper and Deck  
 50 Gallon Rectangular Fuel Tank  
 Front Tow Hooks  
 (2) G31, 600CCA, Low Maintenance Batteries  
 3 Tank, FMVSS Style Split Brake System  
 Rear Frame Rails Extend Beyond Crossmember  
 Automatic Slack Adjusters

## TJ7000 Off Road

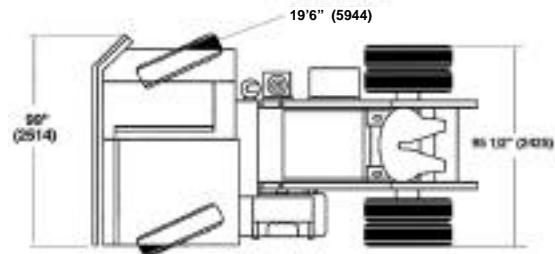
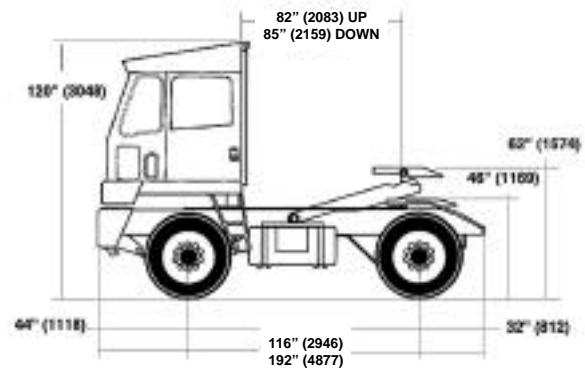

Some items shown represent optional equipment. Due to ongoing Engineering improvements, Capacity reserves the right to make changes without notification. Capacity is a subsidiary of Collins Industries, Inc.

Distributed by:

Capacity of Texas, Inc. • 401 Capacity Drive • Longview, Texas 75604-5341  
 1-800-323-0135 • www.capacitytexas.com